

C15E-380V-11kW

技术参数 Technical Parameter	
名称 Type	参数 Parameters
排气量 Displacement	1670 L/min
排气压力 Exhaust pressure	0.8 MPa
电机功率 Motor power	11 kW
电机转速 Motor speed	2200 r/min
电压/频率 Voltage/Frequency	380V/50Hz
1米处噪音值 Noise level at 1m	≤68±3 dB(A)
电机防护等级 Motor protection class	IP 23
冷却方式 Cooling method	风冷 air-cooled
润滑油油量 Amount of lubricant	10 L
出口气体润滑油携带量 Oil carrying capacity of outlet gas	≤ 3ppm
启动方式 Start mode	变频启动 Frequency starting
出口尺寸 Outlet size	RP1 "
重量 Weight	400kg
冷却后出口压缩空气温度 Compressed air temperature at outlet after cooling	环境温度+12C°
储气罐 tank	300L
外形尺寸 Outline dimension (L*W*H)	1580*830*1485mm
配置清单 Configuration Listing	
名称 Name	品牌 Brand
集成压缩机主机 Integrated Compressor engine	CHANUN
油分桶 Oil separation drums	JINSU
进气阀 Inlet valve	HONGXING
压力阀 Pressure valves	HONGXING
冷却器 Coolers	LAILI
风机 Fans	YUANXIANG
空滤 Air filter	CHANUN
油滤 Oil filter	CHANUN
油分芯 Oil separation core	CHANUN
油滤座 Oil filter holder	CHANUN
压力传感器 Pressure sensor	OULID
温度传感器 Temperature sensors	OULID
安全阀 Safety valves	YANFENG
控制器 Controllers	INOVANCE
变频器 Frequency converter	INOVANCE

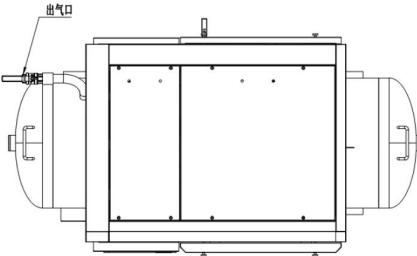
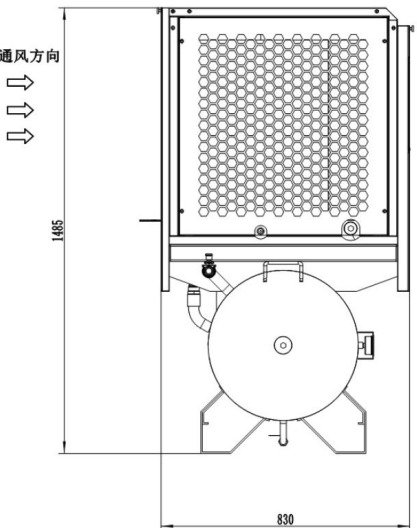
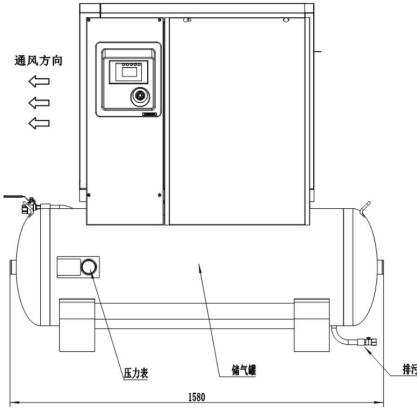

<http://www.chanun.com.cn>
 24H TEL: 400-691-9399