



CHANUN Portable Compressor C10PG

移动式螺杆压缩机

www.chanun.com.cn



扫描二维码，关注官方公众号



扫描二维码，关注官方抖音号

► 技术参数 / Technical specifications

汽油驱动螺杆空压机 / Petrol engine version

型号 Model	压缩机 Compressor				汽油发动机 Petrol engine			油箱 容量 Fuel tank capacity	重量 weight	外形尺寸 Overall dimension	出气口尺寸 Compressed air outlet	
	流量 Flow rate		工作压力 Operating pressure		品牌 Brand	型号 Type	发动机 额定功率 Engine rated power					转速 Speed at full load
	m ³ /min	CFM	bar	PSI			kW					rpm
C10PG	0.98	35	8	116	Honda	GX390	8.2	3600	6.1	260	1150*860*830	G1/4

► 外形尺寸图 / External Dimensions

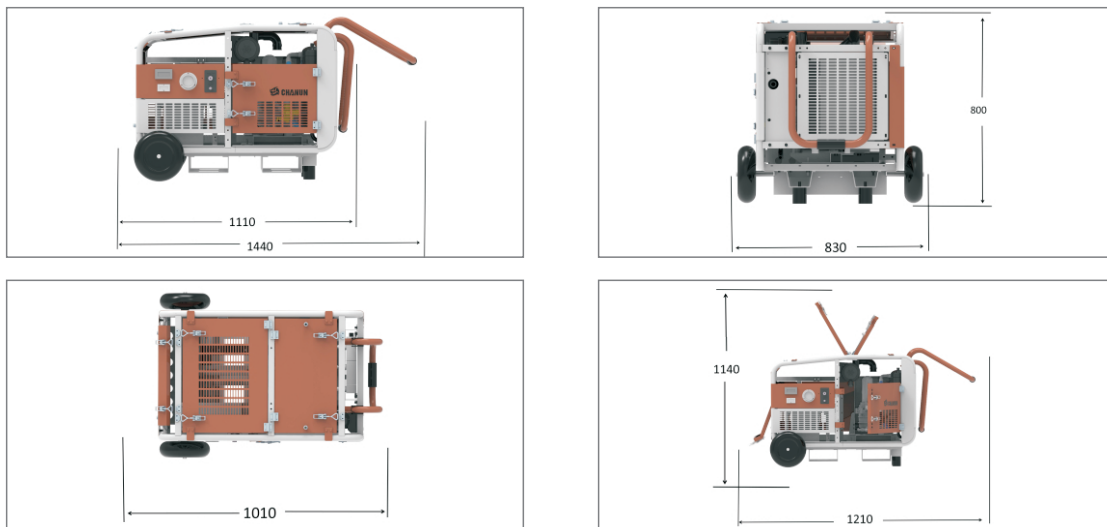

► 晨恩移动式螺杆空压机 / CHANUN Portable Compressors

晨恩汽柴油驱动移动式螺杆空压机设计紧凑，性能卓越，用途极为广泛，强劲的性能不会给您带来多余的不便与繁重的体力劳动。

本机型适用于高达+40°C的环境温度，它们可以为气动铲、气钻、气锯、气动扳手、磨床、冲击钻孔机和管道检测机器人提供所需的能量。

此外，为了尽可能满足广泛的海内外市场需求，晨恩还可选配多种类汽油和柴油引擎动力。

Compact in design, high in performance and extremely versatile, heavyweight performance does not necessarily carry the burden and inconvenience of high operating weight.

Suitable for ambient temperatures up to +40°C, they can provide the required energy for circuit breakers, pneumatic shovels, pneumatic drills, pneumatic saws, pneumatic wrenches, pneumatic drills, saws, spanners, grinders, impact drills and pipe inspection robots.

In addition, to meet the widest possible range of needs, Chanun also offers petrol and diesel engine versions.